

# BAGGAGE SCANNER

## AGS-BS550

### Product highlights:



- \* Multilingual operation
- \* Automatic built in test and self diagnosis
- \* Secure access Key
- \* Continuous working 10000 hours above
- \* Threat alert and material classification
- \* International standard configuration:
- \* Japan Hamamatsu detection and UK Senstech board
- \* Network-Ready
- \* Energy saving design
- \* One key turn off
- \* Drugs and explosives inspection
- \* Indication of the date and time

### Dimensiona Drawing:

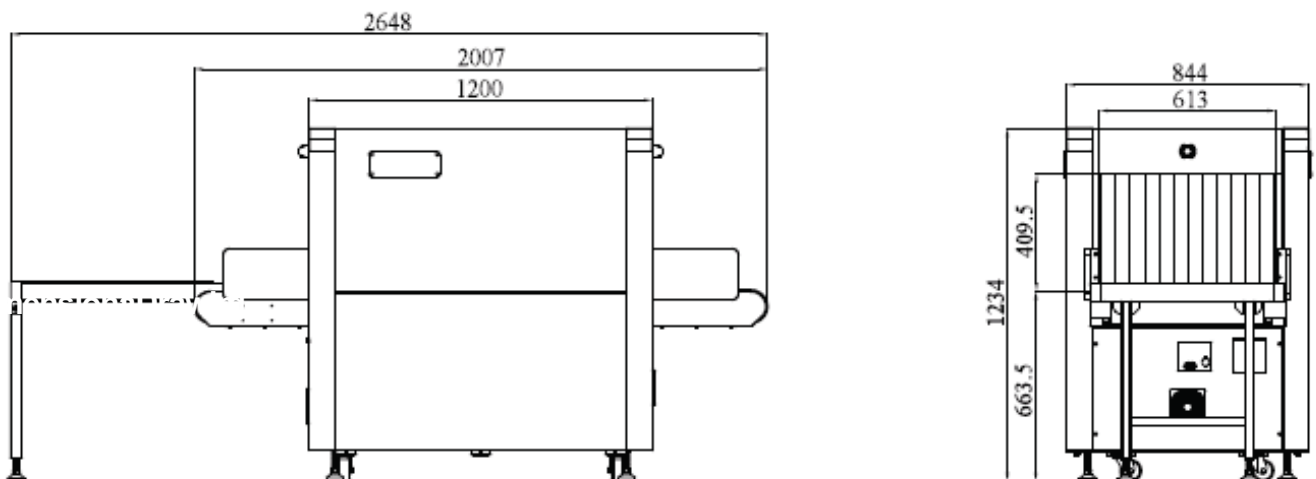

Important Sizes :  
Product Size: 2648\* 844 \* 1234mm (L x W x H)  
Tunnel Size: 613\* 409.5mm (width x height)



## General Specifications:

Wire Resolution	Typical AWG40
Penetration resolution	Typical AWG34
Spatial resolution	Vertical: 1.0mm, horizontal: 1.0mm
Penetration	38mm
Resolution of organic matter	1 - 120 mm
Grayscale and mixture resolution	1 - 60mm
Resolution of inorganic objects	0.2-14mm
Effective material resolution	Meet the requirements of GB15208.1-2005
X-Ray dosage each inspection	≤ 4.5 μSv(uGy)
Boundary Leakage	≤ 0.5 μSv/h(uGy/h)
S/N ratio	<60dB
Conveyor speed	0.2m/s
Conveyor max load	160kg
Power consumption	0.8KVA
Safety performance requirements	Meet the requirements of GB15208.1-2005
EMC requirements	Meet the requirements of GB15208.1-2005
Electrical safety	Meet the requirements of GB15208.1-2005
Environmental applicability	Meet the requirements of GB15208.1-2005
Leakage current	≤ 5.0mA
Film Safety	Guarantee ASA/ISO1600 Film
Weight	455kg
Operation temperature/Humidity	5°C- 40°C/0%-90%
Storage temperature/Humidity	-20°C-60°C/10%-90%
Atmospheric pressure	86kPa-106kPa
Operation Power	AC220V(±10% -15%) 50±3Hz
Operation system	Windows XP



## Configuration:

X ray generator	160KV, oil cooling, from bottom to top
Electric roller	Three-phase
Computer	CPU: Intel Celeron 2.60-2.70GHz, Hard drive: 500G, Storage : 2G
Monnitor	21.5" LED screen, resolution: 1280*1024 pixels
Operation console	Single screen console



## Scanned images:

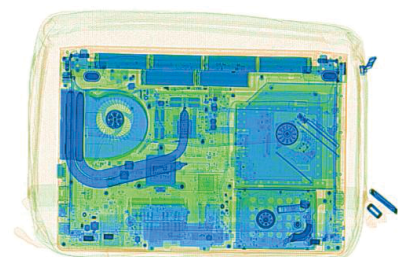
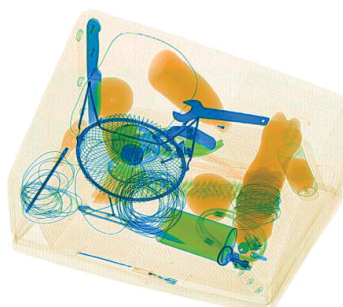
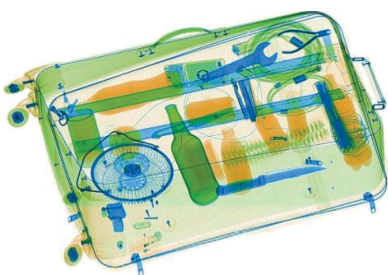



## Software Functions:

Power-on self-test	With the function of fault self-check, automatically judge the fault and prompt the fault code information in time.
Image processing	With the function of Color/BW, negative, high/low penetration, organic/inorganic stripping, general enhancement, and pseudocolor, etc.
Image Recall	30 preceding images recallable.
The number of images stored	Up to 10,000 images stored automatically.
Image management	With the functions of image information query, open, export and print, 6 image formats can be exported (JPG, BMP, XF, PNG, TIFF, GIF)
Operator management	Operators can be added and deleted, and operator names, groups, passwords, enabled status can be modified, and usage logs can be exported.
Dangerous goods image insertio	TIP insertion pictures can be added and deleted, TIP enable status, injection interval, floating range, motion determination time, and stationary determination time can be set; the user can check the operator by recording information.
Equipment diagnosis	Key components of equipment can be diagnosed through the diagnostic interface, including detector, motor positive and negative rotation, infrared sensor, special keyboard, etc.
System Settings	Programmable key, imaging display (horizontal, vertical image, maximum magnification, display recovery), scanning mode setting (two-way, direction, strong scanning, energy saving), auxiliary inspection (difficult to penetrate, explosives, drugs), luggage counter function Settings.
System equipment information	Display software version, equipment model, factory number, scan count, power on time, beam out time, image file storage capacity and other information. Able to conduct automatic through-baggage training for new operators.
Training function	Able to conduct automatic through-baggage training for new operators.



## Compliance:

International	<ul style="list-style-type: none"> <li>* ISO19001 ; ISO14001 ; ISO27001 ; OHSMS18001 ;</li> <li>* CE , ROHS, FCC, REACH</li> <li>* USA, FDA</li> </ul>
National	<ul style="list-style-type: none"> <li>* Health Inspection Report</li> <li>* Computer Software Copyright Registration Certificate</li> <li>* Software Product Registration Certificate</li> <li>* Radiation Safety Certificate from Ministry of Public Security</li> <li>* Quality Certification from Safety and Police Electronic Products Quality Inspection Center</li> <li>* Design patent certification</li> </ul>